

Material hormigón Petra 2 + hierro imprimación antioxidante + + retroreflectantes
Acabado decapado e hidrofugado
Dimensiones Ø 68, h. 110 cm
Color ver carta de colores
Fijación apoyado por su propio peso o mediante resina epoxi
Peso 497 Kg
Palet 70 x 70 cm

Material precast concrete Petra 2 + iron with rust-resistant primer + retroreflective
Finish scaled and waterproofed
Dimensions Ø 68, h. 110 cm
Colour see colour catalogue
Fixing resting on the ground or with epoxy resin
Weight 497 Kg
Pallet 70 x 70 cm

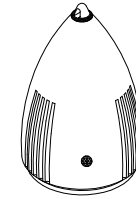

GEOMETRIA / GEOMETRY

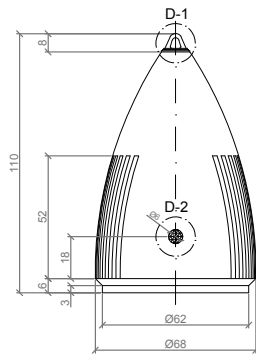

ALZADO / FRONT VIEW

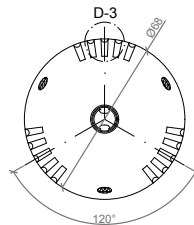

PLANTA / TOP VIEW

ESPECIFICACIONES / SPECIFICATIONS

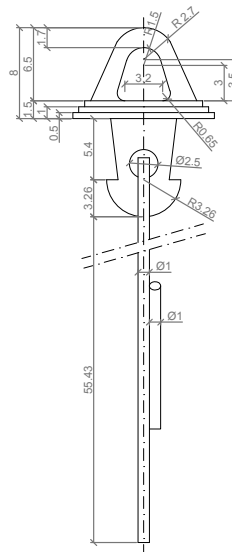

ALZADO / FRONT VIEW

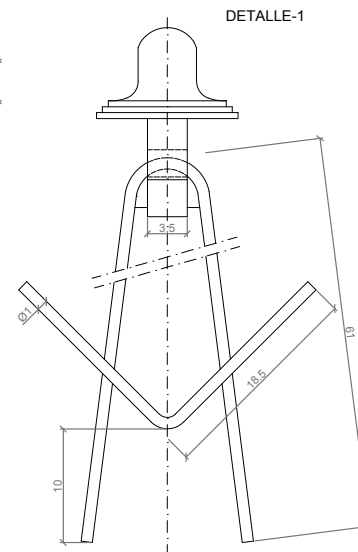

PERFIL / PROFILE VIEW

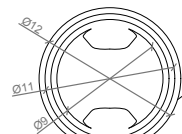

PLANTA / TOP VIEW

Hierro imprimación antioxidante
Iron with rust-resistant primer

DETALLE-2

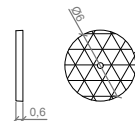

Dispositivos retroreflectantes
76 / 757 / CEE
Retroreflective
76 / 757 / CEE

DETALLE-3

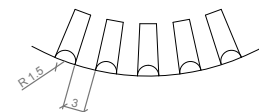

MANIPULACIÓN E INSTALACIÓN /
HANDLING AND INSTALLATION

Elevación / Hoisting
P= 497 Kg

