

CARACTERÍSTICAS / FEATURES

Material hormigón Petra 1
Acabado decapado e hidrofugado
Dimensiones l. 80, a. 80, h. 48 cm
Color ver carta de colores
Fijación apoyado por su propio peso y con resina epoxy
Peso 394 Kg
Palet 100 x 100 x 65h cm
Peso palet 410 Kg

Material concrete Petra 1
Finish scaled and waterproofed
Dimensions l.80, w.80, h. 48 cm
Colour see colour catalogue
Fixing by its own weight and with epoxy resin
Weight 394 Kg
Pallet 100 x 100 x 65 cm
Weight pallet 410 Kg

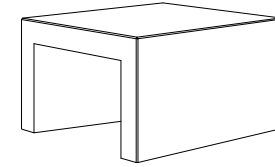

GEOMETRIA / GEOMETRY

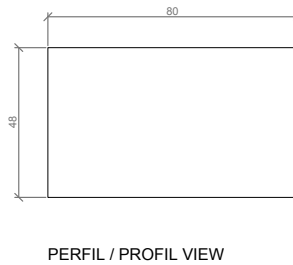
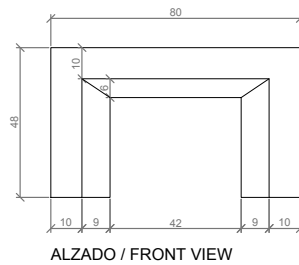
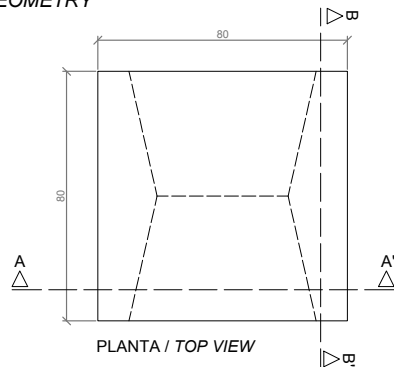

**MANIPULACIÓN E INSTALACIÓN
HANDLING AND INSTALLATION**

- 1 elevar y enroscar la varilla / lift and thread the rod

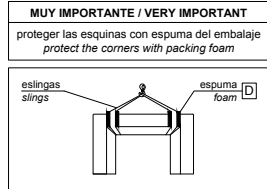

elevación / hoisting
P= 394 Kg

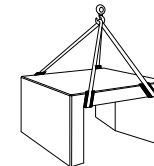

- 2 verter resina epoxy / pour epoxy resin

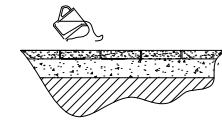

- 3 colocar el banco / place the bench

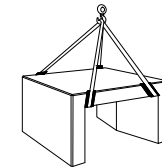

ESCALA / SCALE 1/15

ESPECIFICACIONES / SPECIFICATIONS

