

CARACTERÍSTICAS / FEATURES

Material SMC
Acabado liso
Dimensiones l. 200, a. 53, h. 72 cm
Color ver carta de colores
Fijación con varillas metálicas y resina epoxy
Peso 134 Kg
Palet 210 x 70 x 85h cm
Peso palet 170 Kg

Material SMC
Finish smooth
Dimensions l.200, w.53, h. 72 cm
Colour see colour catalogue
Fixing anchored with metal rods and epoxy resin
Weight 134 Kg
Palet 210 x 70 x 90 cm
Weight palet 170 Kg

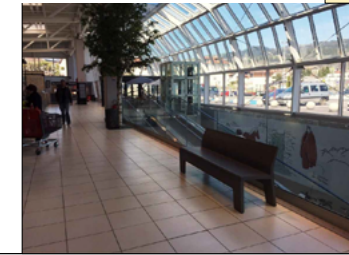
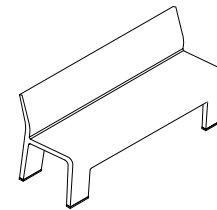

GEOMETRIA / GEOMETRY

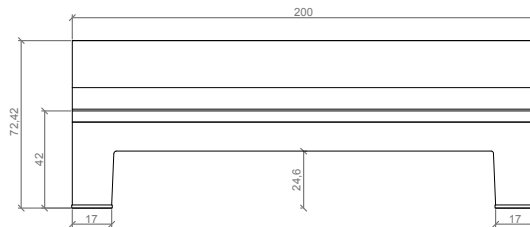

ALZADO / FRONT VIEW

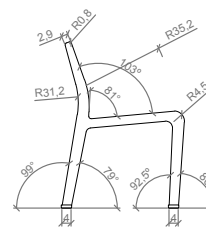

PERFIL / SIDE

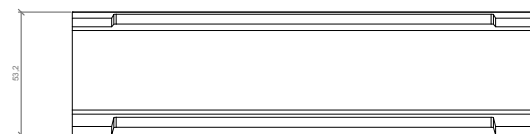

VISTA INFERIOR / BOTTOM VIEW

ESCALA / SCALE: 1/20

MANIPULACIÓN E INSTALACIÓN / HANDLING AND INSTALLATION

Elevación / Hoisting
P= 134 Kg

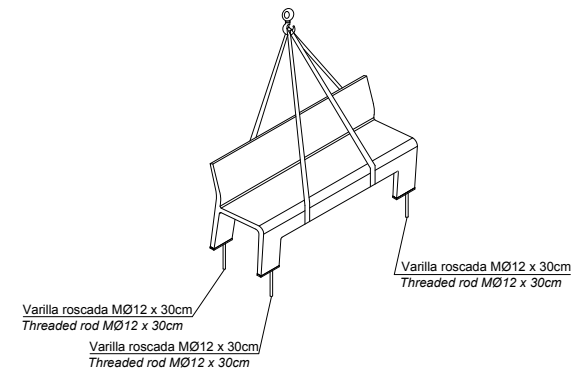

Varilla roscada MØ12 x 30cm
Threaded rod MØ12 x 30cm

Varilla roscada MØ12 x 30cm
Threaded rod MØ12 x 30cm

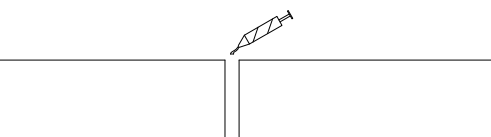

Perforar agujero MØ14 y verter resina epoxy
Drill hole MØ14 and pour epoxy resin

ESPECIFICACIONES / SPECIFICATIONS

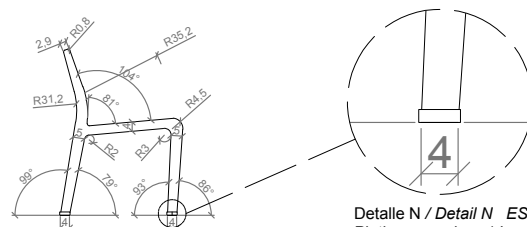

Detalle N / Detail N ESC:1/5
Pletina acero inox / Inox Plate

ESCALA / SCALE: 1/20