

CARACTERÍSTICAS / FEATURES

Material	hormigón Petra 1	Material	precast concrete Petra 1
Acabado	decapado e hidrofugado	Finish	scaled and waterproofed
Dimensiones	l. Ø130, h. 50 cm	Dimensions	l. Ø130, h. 50 cm
Color	ver carta de colores	Colour	see colour catalogue
Fijación	simplemente apoyado o mediante resina epoxi	Fixing	resting on the ground or with epoxy resin
Peso	275 Kg	Weight	275 Kg
Palet	140x140x65h cm	Pallet	140x140x65h cm
Peso palet	310 Kg	Weight pallet	310 Kg

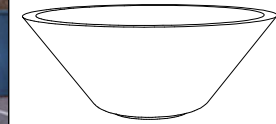

GEOMETRIA / GEOMETRY

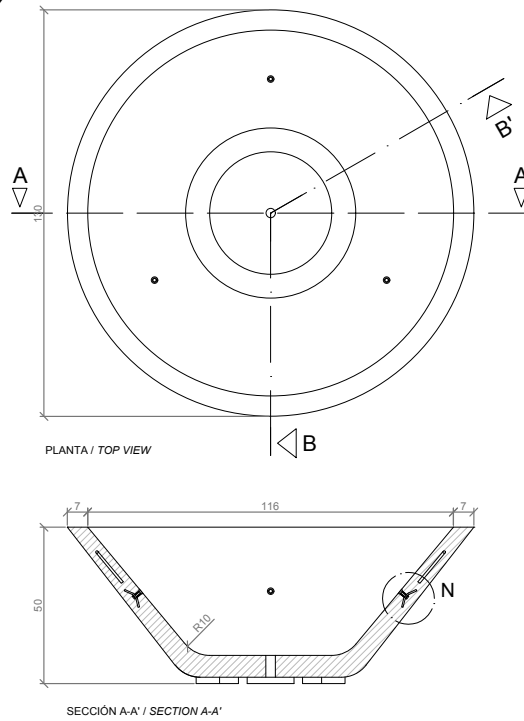

ESCALA / SCALE : 1/ 15

MANIPULACIÓN E INSTALACIÓN / HANDLING AND INSTALLATION

Elevación / Hoisting
P= 275 Kg

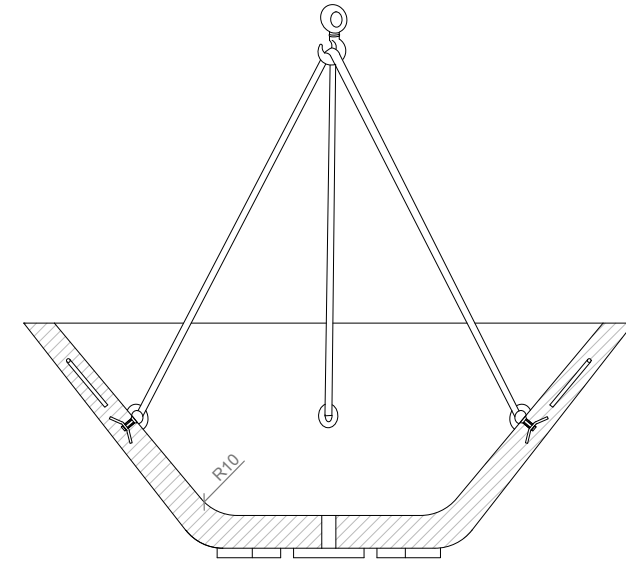

ESPECIFICACIONES / SPECIFICATIONS

Tornillo avellanado M12
Countersunk screw M12

Casquillo M12 - Acero zincado alta precisión
Threaded sleeve M12 - Galvanized steel high precision

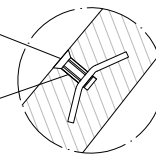

DETALLE N / DETAIL N