

CARACTERÍSTICAS / FEATURES

Material hormigón Petra 1
Acabado decapado e hidrofugado
Dimensiones l. 200, a. 80, h. 45 cm
Color ver carta de colores
Fijación simplemente apoyado
Peso 790 Kg
Palet 210 x 90 cm

Material precast concrete Petra 1
Finish scaled and waterproofed
Dimensions l.200, w.80, h. 45 cm
Colour see colour catalogue
Fixing resting on the ground
Weight 790 Kg
Pallet 210 x 90 cm

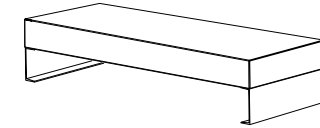
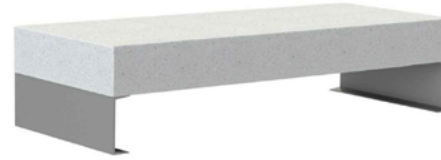

GEOMETRIA / GEOMETRY

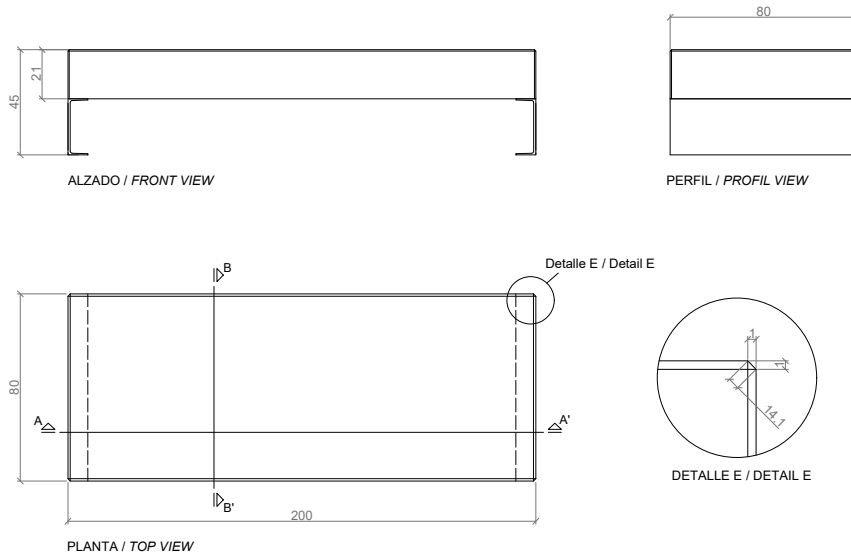

MANIPULACIÓN E INSTALACIÓN / HANDLING AND INSTALLATION

Elevar el banco mediante eslingas y instalar / Lift the bench with slings and install

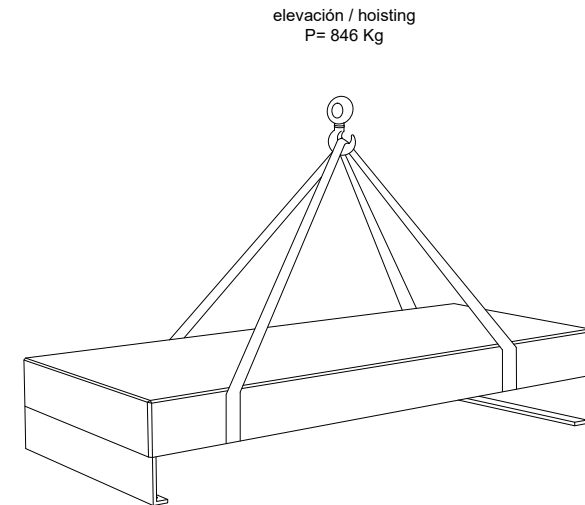

ESCALA / SCALE : 1/20

ESPECIFICACIONES / SPECIFICATIONS

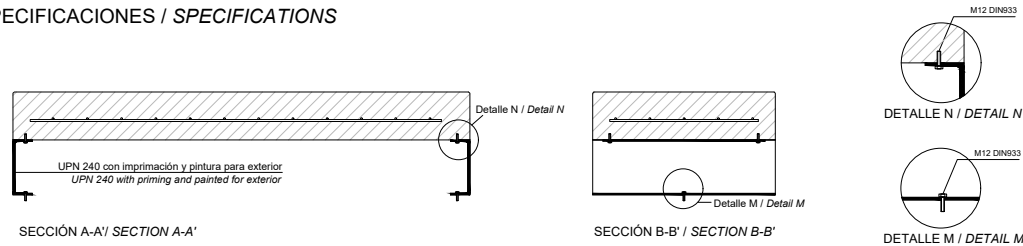

ESCALA / SCALE : 1/20

DETALLES / DETAILS

